

FLAMEPROOF BARRIER CABLE GLAND ASSEMBLY INSTRUCTIONS FOR GROUP I AND II BXN, BXC, BXM, BXA TYPES.

Rif No IBX RCN16000R2 del 19-03-2018

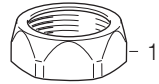
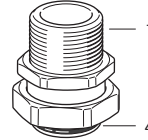
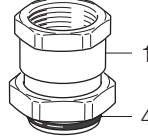
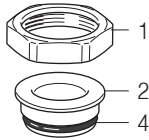

Certifications:

Approved for II2GD, I M2,

Ex db I Mb, Ex db IIC Gb,

Ex eb I Mb, Ex eb IIC Gb,

Ex tb IIIC Db;

CESI 14ATEX069X

IECEx CES15.0001X;

Ambient temperature range:

-60°C up to + 110°C

Service temperature range:

-60°C up to + 130°C

Ambient/service temperature

ranges restricted up to -20°C for AVP steel made.

BXN Type

Backnut - 1

Compression ring - 2

O-Ring - 4

O-Ring - 5

Compound - 6

Container

Body - 7

BXC Type

Backnut - 1

O-Ring - 4

O-Ring - 5

Compound - 6

Container

Body - 7

BXM Type

Backnut - 1

O-Ring - 4

O-Ring - 5

Compound - 6

Container

Body - 7

BXA Type

Backnut - 1

Compression ring - 2

Mouth - 3

O-Ring - 4

O-Ring - 5

Compound - 6

Container

Body - 7

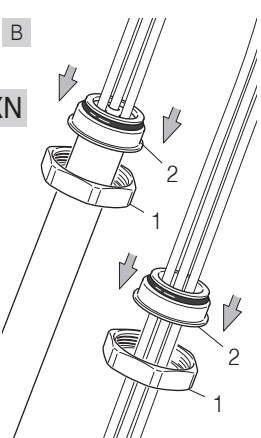
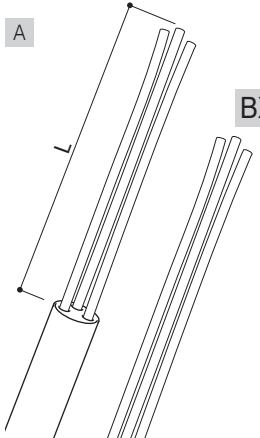

Bring the conductors to an "L" length as required by the equipment. Twist together to get the maximum flexibility.

Insert the backnut (1) and the compression ring (2) in the cable or conductors.

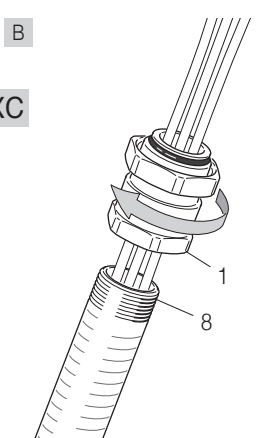
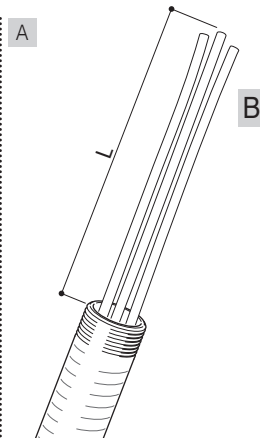

Bring the conductors to an "L" length as required by the equipment. Twist together to get the maximum flexibility.

Screw the backnut (1) to the conduit (8).

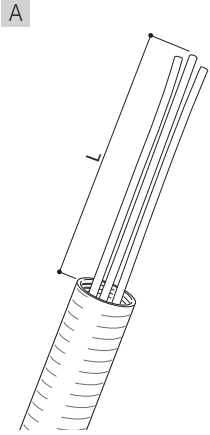

A

BXM

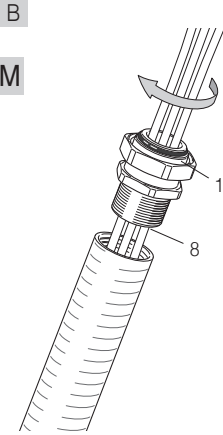

B

Screw the backnut (1) to the conduit (8).

Bring the conductors to an "L" length as required by the equipment. Twist together to get the maximum flexibility.

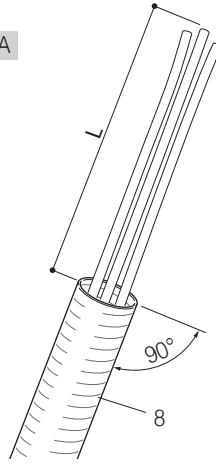

A

BXA

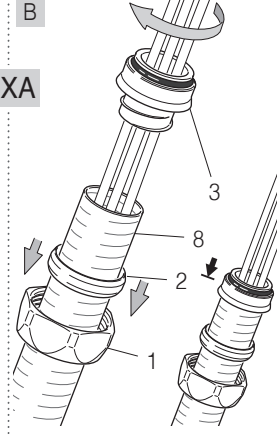

B

Preparation of the Conduit (8)
Cut the conduit at 90° using a hacksaw. Bring the conductors to an "L" length as required by the equipment. Twist together to get the maximum flexibility.

Insert the backnut (1) and the compression ring (2) in the conduit. Insert the bushing (3) through the conductors and screw the conduit (8) until it stops.

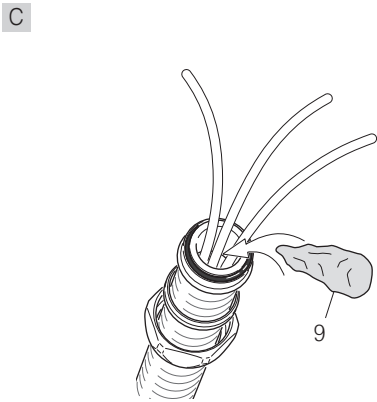

C

Spread the conductors for applying the compound. Apply the compound (9) between the conductors as shown. (See notes at the back for the preparation of the compound)

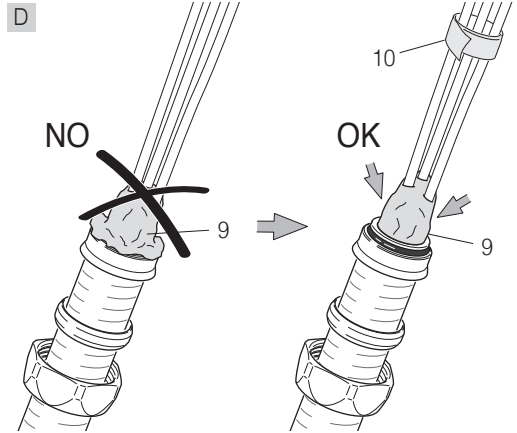

D

After having filled in all of the spaces, bring the conductors back together and apply more resin around the outside of the conductors, as shown in Fig. D. Secure the conductors together with tape (10) to prevent the resin from separating them.

E

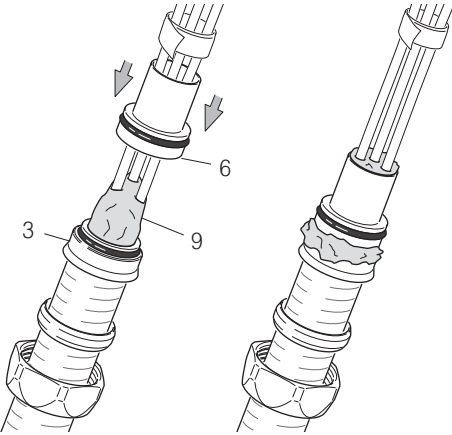

Insert the container (6) making sure that the O-Ring is intact and in the correct position and push up until it has been inserted. Bring the components in full contact. Push the excess resin inside the container and add if necessary.

F

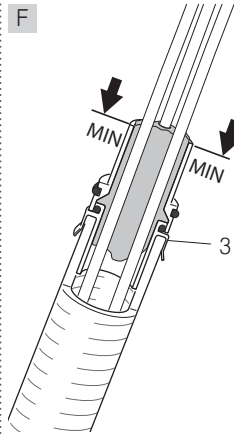

Important: Make sure the resin completely fills the inside of the bushing (3).

G

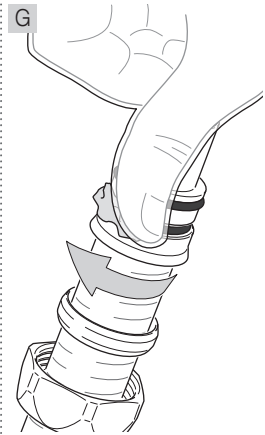

Remove the excess resin. **Note:** It is important that all the resin residue, outside of the container, is removed.

H

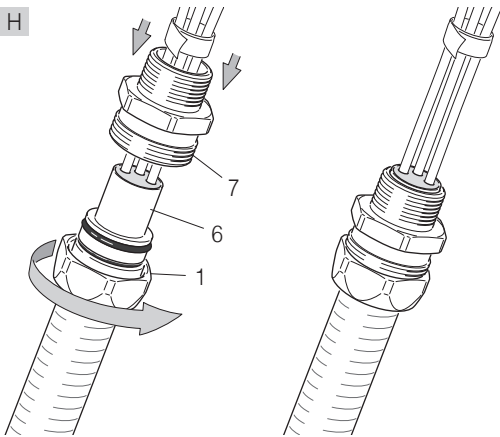

Insert everything through the body (7), which may have been previously screwed to the equipment. Make sure that the resin does not overlap the side of the container (6). Tighten the backnut (1) to the body using a wrench to the value shown on table 1.

I

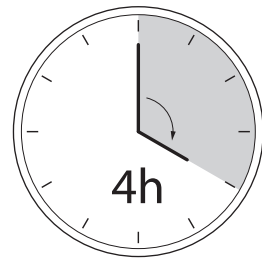

Allow the compound to harden

Important: The conductors must not be moved for at least four hours.

3 to 4 hours are necessary at a temperature of between 20°C and 30°C so that the compound solidifies. They have to spend 12 to 24 hours at a temperature of between 20°C and 30°C until the compound reaches an optimal state.

Preparation of epoxy resin

To use the compound, wear gloves provided with the resin.

The epoxy resin is provided in a package with two separate parts. These must be mixed in a ratio of 1:1 until the compound is a single color and without streaks.

The best solution for mixing the two parts is by rolling and bending the components several times together. Once mixed, the resin must be used within 30 minutes. Over time it will begin to harden. The compound should not be stored at a temperature below 20°C before being mixed. At lower temperatures, it will

becomes difficult to mix.

If the compound comes in contact with one's skin, it must be removed with a detergent and in no case allowed to harden.

Mix only enough compound to assemble one cable gland at a time.

The compound may be adversely affected by certain solvent fumes. If these fumes are present in the vicinity of the cable glands in service, specific precautions may be necessary. The compound polymerizes to a Shore hardness of 85. If used in the cable gland, as shown here, the compound, when

completely set, is suitable to use at a range of service temperatures from -60°C to +130°C. Note: Consider that the setting time may be longer when the room temperature is below 20°C.

Epoxy resin kit EPR+EPH 50gr		
Size	Recommended quantity	
16	1 x 50gr	
20	1 x 50gr	
25	1 x 50gr	
32	1 x 50gr	
40	2 x 50gr	
50	2 x 50gr	

Size	Body (7)		Backnut (1)		Tightening torque (Nm)	Thread ISO 262	Thread ISO 228	Thread DIN 40430	Thread NPT	Thread Gk	Thread ISO 10226	Max over multi cores	Max o ext. conductor	Max no conductors
	Wrench	Edge	Wrench	Edge										
16	25	27	26	29	4	M16x1.5 M20x1.5	G3/8" G1/2"	Pg 11 Pg 13.5	3/8" 1/2"		R3/8" R1/2"	9.4	8	10
20	28	30.8	30	33	6	M20x1.5	G1/2"	Pg 16	1/2"	Gk1/2"	R1/2"	12.4	10.5	15
25	34	38	35	38.7	8	M25x1.5	G3/4"	Pg 21	3/4"	Gk3/4"	R3/4"	17.6	14	30
32	43	47	45	50	12	M32x1.5	G1"	Pg 29	1"	Gk1"	R1"	22.8	18.5	50
40	52	57	55	60	24	M40x1.5	G1 1/4	Pg 36	1 1/4	Gk1 1/4	R1 1/4	28	24.5	75
50	55	61	57	63	30	M50x1.5	G1 1/2	Pg 36	1 1/2	Gk1 1/2	R1 1/2	34.5	29.5	80

BXC BACKNUT THREADS						
Size	Thread ISO 262	Thread ISO 228	Thread DIN 40430	Thread NPT	Thread Gk	Thread ISO 10226
16	M16x1,5	G3/8"	Pg11	3/8"		R3/8"
20	M20x1,5	G1/2"	Pg13,5	1/2"	Gk1/2"	R1/2"
25	M25x1,5	G3/4"	Pg16	3/4"	Gk3/4"	R3/4"
32	M32x1,5	G1"	Pg21	1"	Gk1"	R1"
40	M40x1,5	G1 1/4	Pg29	1 1/4	Gk1 1/4	R1 1/4
50	M50x1,5	G1 1/2	Pg36	1 1/2	Gk1 1/2	R1 1/2

BXM BACKNUT THREADS						
Size	Thread ISO 262	Thread ISO 228	Thread DIN 40430	Thread NPT	Thread Gk	Thread ISO 10226
16	M16x1,5	G3/8"	Pg11	3/8"		R3/8"
20	M20x1,5	G1/2"	Pg13,5	1/2"	Gk1/2"	R1/2"
25	M25x1,5	G3/4"	Pg16	3/4"	Gk3/4"	R3/4"
32	M32x1,5	G1"	Pg29	1"	Gk1"	R1"
40	M40x1,5	G1 1/4	Pg36	1 1/4	Gk1 1/4	R1 1/4
50	M50x1,5	G1 1/2	Pg36	1 1/2	Gk1 1/2	R1 1/2

STANDARD THREAD TABLE - IDENTIFICATION ABBREVIATIONS																										
ISO 262-M	M12x1,5	I12	M16x1,5	I16	M20x1,5	I20	M25x1,5	I25	M32x1,5	I32	M40x1,5	I40	M50x1,5	I50	M63x1,5	I63	M75x1,5	I75	M80x2	I80	M85x2	I85	M90x2	I90		
ISO 228-G	G1/4	B12	G3/8	B16	G1/2	B20	G3/4	B25	G1"	B32	G1 1/4	B40	G1 1/2	B50	G2"	B63	G2 1/2	B75						G3"	B90	
DIN 40430-Pg	Pg7	P12	Pg9	P16	Pg11	P20	Pg13,5	P25	Pg16	P32	Pg21	P40	Pg29	P50	Pg36	P63	Pg13,5	P75							Pg48	P90
ANSI B1.20.1-NPT	1/4 NPT	N12	3/8 NPT	N16	1/2 NPT	N20	3/4 NPT	N25	1" NPT	N32	1 1/4 NPT	N40	1 1/2 NPT	N50	2" NPT	N63	2 1/2 NPT	N75							3" NPT	N90
*Gk					Gk1/2	U20	Gk3/4	U25	Gk1"	U32	Gk1 1/4	U40	Gk1 1/2	U50	Gk2"	U63	Gk2 1/2	U75							Gk3"	U90
*ISO 10226	R1/4	R12	R3/8	R16	R1/2	R20	R3/4	R25	R1"	R32	R1 1/4	R40	R1 1/2	R50	R2"	R63	R2 1/2	R75							R3"	R90

Equipment Series

Cable gland series: BXC, BXM, BXA; Certificate ATEX: C6S1 14 ATEX069X, Certificate IECEx: CES 15.0001X

- Cable glands for the above-mentioned series are suitable for unarmored cables and for all of the cable entries a part of the electrical equipments of groups I and II, category M2 or 2 GD (ATEX Directive), with type of protection Ex d I Mb, Ex e I Mb, Ex d IIA/IIb/IIc Gb, Ex e IIC Gb and Ex tb IIC Db (ATEX Directive and IEC Ex Scheme); ambient temperature range: -60°C to +110°C, service temperature range: -60°C to +130°C. These cable glands are suitable for use on Ex d IIC enclosures with volumes greater than 2 dm³.

- Ex db IIC Gb, Ex eb IIC Gb, Ex tb IIC Db, Ex db I Mb, Ex eb I Mb execution in accordance with Standards EN 60079-7:2012/A11:2013 / EN 60079-1:2014

- EN 60079-7:2015 / EN 60079-31:2014 / IEC 60529:1991 (ATEX), IEC 60079-0:2011 / IEC 60079-1:2014 / IEC 60079-7:2015 / IEC 60079-31:2013 / IEC 60529:1989 + A1:1999 + A2:2013 (IECEx)

- The cable gland's degree of protection is IP66 or IP68/68 at 30 meters deep for 7 days according to IEC 60529, EN 60529 Standards; the degree of IP 68 protection is obtained by using flat sealing rings on the cable glands with cylindrical threads. Without the seals, the degree of protection is IP 66. If the cable glands with cylindrical or conical threads are screwed on the threaded hole of the apparatus, in order to guarantee an IP66 or IP68/68 degree of protection, the threaded parts must be sealed with Loctite 241 on at least two complete threads engaged. In any case the metal continuity should be guaranteed. The installation on an Exe and Extb enclosure with a not threaded hole must be made using a flat seal to guarantee an IP66/68 degree of protection. In order

to maintain the IPX8 degree of protection, the cable entry must be fitted on an enclosure which satisfies a 7-day immersion test in 30 meters of water. Metric cable glands are made in accordance to the EN 50262 Standard.

Installation

- These products must be installed according to the requirements of IEC 60079-14, EN 60079-14 Standards or other national laws or standards. The certificate does not cover uses different from what has been described in the requirements.

- Verify the suitability of the cable glands in respects to the installation zone, group, category (for ATEX), gas group and room ambient/service temperatures.

- User must be aware of the risks related to electrical current and chemical/physical characteristics of the gases and/or vapors and of the dust present at the plant.

- Assembly and tightening of the cable glands should not compromise the degree of protection.

- Verify the integrity and the continuity of the ground, protection and equipotential conductors.

- The Barrier cable glands made of AVP steel or Aluminium alloy are admitted for Group II applications only.

- The Barrier cable glands with M16, 3/8" and Pg11 threads are not admitted for Group I (mines) applications.

On Exd applications, the cylindrical threaded joint should have at least 5 full threads engaged, while on conical threaded joints, the threads for each part must be ≥6, considering the maximum tolerance accepted, the real number of threads within may be less than 5. If cable glands are assembled on a wall with a not threaded holes on an Exe apparatus, the hole diameter must be equal to the nominal external diameter of the

thread, increased by 0.5 mm with an H11 tolerance.

Special Conditions for Safe Use

- Cable glands must be suitable for installed cable diameters, sized according to the nominal current intensity allowed in the electrical circuits.

- The coupling of the Barrier cable glands with the enclosures shall be made as indicated by the manufacturer in order to respect the type of protection of the electrical apparatus on which Barrier cable glands are mounted.

- When the cores will be fitted inside the sealing pot by filling compound, the mounting should guarantee a sufficient quantity of compound around each single core to ensure the clamping of the cemented joint. This shall be done as indicated in the manufacturer instruction.

- The Barrier cable glands series BXA..., BXC..., BXM... and BXCN... have to be protected from hydraulic fluids, oils and greases when applied for Group I (mines) use.

- When the Barrier cable glands type BXA, BXC and BXM are designed for use in Group I (mines) applications:

the cables should be installed in compliance with the requirements of the local code of practice; conduits should provide additional mechanical protection only.

Accessories

Before proceeding with the installation of the cable glands, particular attention must be paid to any accessories which may be deemed necessary, such as: Locknuts for fixing the cable glands in position.

Seals for additional protection of the enclosure with the entry of the cable.

Earth tags providing additional grounding points for the armour or the screen.